



# JULIET

## Swingdoor

Compatible with  
**DELTA and ECHO**



### Description

The d-flexx JULIET Door offers both a strong visual and physical barrier, engineered for use in industrial environments where safety, access control, and clear demarcation are crucial. This versatile door system helps define restricted areas, ensuring pedestrian walkways and operational zones are clearly separated while providing controlled access when required.

### Key Features

**Visible and Physical Protection:** The JULIET Door serves as a highly visible boundary that not only defines the edges of safe areas but also functions as a reliable physical barrier. It effectively prevents unauthorized entry, reduces the risk of accidents and safeguards employees, equipment, and sensitive zones.

**Hydraulic Hinges:** The door can open up to 180° thanks to its high-quality hydraulic hinges, allowing for easy access and smooth operation in various environments.

**Master and Slave Hinges with Adjustable Tension:** The JULIET Door features a master-slave hinge system, where the master hinge controls the primary movement of the door, while the slave hinge follows, ensuring synchronized and balanced opening. The closing mechanism's spring tension can be individually adjusted, allowing users to tailor the door's closing speed and force based on specific operational needs. This flexibility ensures that the door performs optimally in various environments, especially in high-traffic areas where controlled access is important.

**Seamless Compatibility:** The JULIET Door integrates effortlessly with all DELTA and ECHO barrier variants by d-flexx, offering flexibility for adapting or expanding your existing safety infrastructure.

### Technical Information

Operational Temperature Range:	-40°C up to +50°C / -40°F up to +112°F
Ignition Temperature:	350-360°C / 662 - 680°F
Flash Point:	350-360°C / 662 - 680°F
Toxicity:	Nontoxic
Chemical Resistance:	High-ISO / TR 10358
UV Stability	Gray scale: 5/5
Changes to material after 5 years:	Blue Wool scale: 8/8 Tensile strength: No changes
Static Rating (surface resistivity):	1015-1016 Ω
Standard Warranty:	5 Years
Deflection zone:	250mm / 9,84in

### Scan or click to review



Maintenance Guide  
Assembly Guide  
Videos  
Tender Text  
Warranty



## Specifications

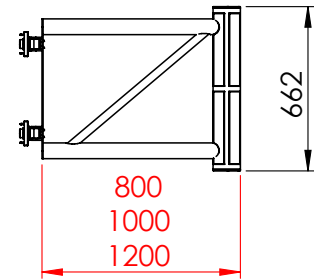
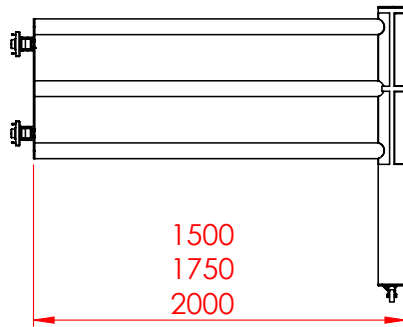
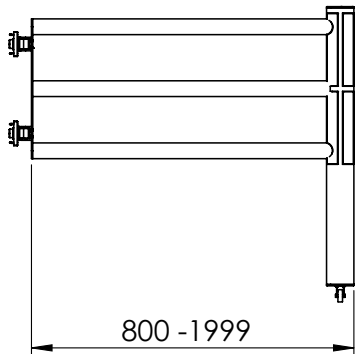

## Measurements mm vs in

	mm	in
Height	662	26,06
Width 1	800-1999	31,50-78,74
Width 2	1500	59,06
Width 3	1750	68,90
Width 4	2000	78,74
Width 5	800	31,50
Width 6	1000	39,37
Width 7	1200	47,24